



shadowspec

umbrellas with distinction

SU4

Cantilever Umbrella

(with 360° Rotation & Tilting functions)

OWNERS MANUAL

Installation, Operation,
Care & Guarantee



SECTION 1 - Installation, Assembly & Operation

Stage 1 - Planning the Umbrella Location	3
- Dimensions	4
Stage 2 - Selection & Installation of the Umbrella Fixing	5
- Option 1 - In-Ground Anchor	6
- Option 2 - Surface Plate (Concrete Mount)	7
- Option 3 - Surface Plate (Timber Deck Mount)	8
- Option 4 - Portable Base	9
Stage 3 - Assembling Notes	10
Stage 4 - Operating the Umbrella	11

SECTION 2 - Umbrella Care & Maintenance **14****SECTION 3 - Warranty** **15**

SECTION 1 – Installation, Assembly & Operation

STAGE 1 - Planning the Umbrella Location

Special care is needed when selecting the best location for your umbrella. Some key points to keep in mind are:

- Ensure that the location you have chosen has the umbrella in a position where it provides the best possible coverage over the area that you want shaded.
- Remember the SU4 has the ability to tilt and rotate 360° so if you wish to utilise this function ensure that you allow the necessary space around the umbrella for this. (see Figure 1).

Figure 1

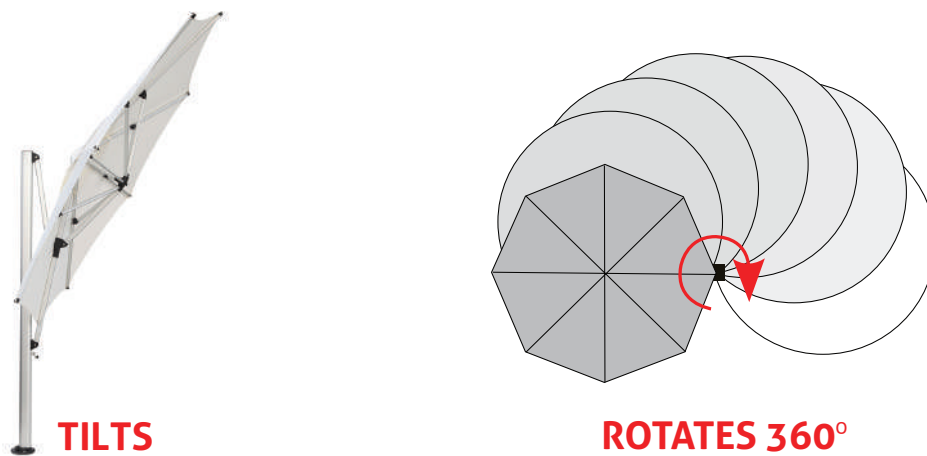

DIMENSIONS:

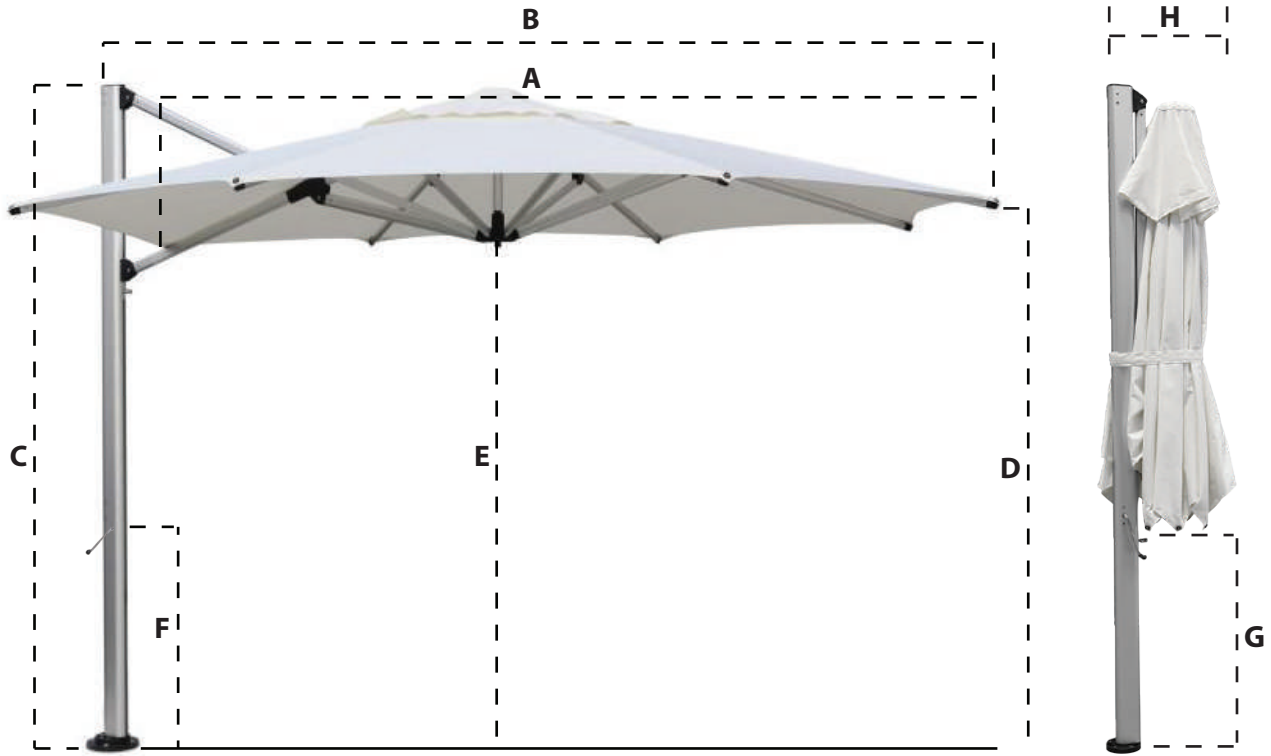

SU4	A	B	C	D	E	F	G	H
3.5m/11'5" Octagon	3.480m/11'4"	3.595m/11'8"	2.723m/8'11"	2.125m/7'0"	2.065m/6'8"	0.940m/3'1"	0.880m/4'7"	0.450m/1'5"

NOTE: All measurements are rounded and are subject to change.

STAGE 2 - Selection & Installation of the Umbrella Fixing

Now that you have selected a location for your umbrella the next step is to ensure that you have ordered the correct fixing option for your umbrella. There are three options available:

- In-ground Anchor
- Surface Plate
- Portable Base

If you are unsure as to what fixing requirements will be needed for your location please contact us (refer contact details on back cover of this manual).

Having confirmed that the fixing option you have chosen is suited to the planned location of your umbrella you are now ready to install the fixing.

Following are four common install scenarios as a general guide for installation. Note that these are provided as a guide only.

OPTION 1 - In-Ground Anchor

STEP 1 Preparation

The in-ground anchor needs concreting in the ground as per the diagram (right). The 1.0m deep x 0.5m wide hole size recommended assumes the terrain is thick clay. Should the terrain be fine soil or sand, the hole size should be increased. The recommended installation requires approximately .50 cubic meters of concrete for silty or fine soil and approximately .25 cubic meters of concrete for heavy clay.

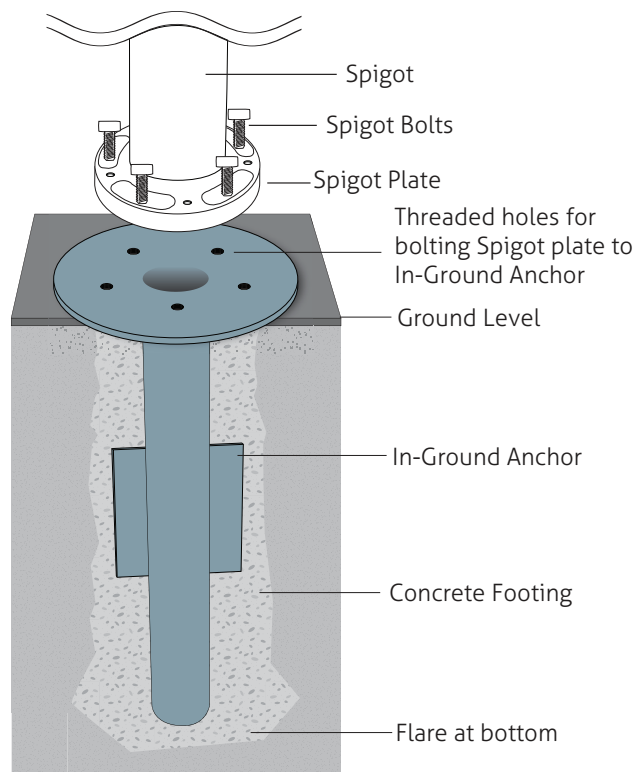

STEP 2 Bolt Spigot to In-ground Anchor

Once the concrete is cured, bolt the spigot plate to the in-ground anchor plate using the five (5) spigot bolts included with umbrella. Insert the spigot bolts downward through the holes in the spigot plate and screw them into the threaded holes in the in-ground anchor. The spigot bolts should be left just loose enough to allow final adjustment of the orientation of the umbrella if necessary, then once correctly orientated, fully tighten the spigot bolts.

You are now ready to operate your umbrella!

IMPORTANT: When concreting the in-ground anchor in place, make sure not to get slurry in the screw threads. Either apply tape over the holes on both sides of the anchor or place the spigot bolts in the threads and withdraw them with the concrete is set. Make sure that the in-ground anchor is perfectly level. Allow the concrete to cure for the appropriate cure time for your area before installing the umbrella onto the fitting.

REMOVAL:

To remove your umbrella for seasonal storage or to move it to another surface plate/ in-ground anchor, simply undo the spigot bolts and remove the umbrella from the in-ground anchor.

OPTION 2 - Surface Plate (Concrete Mount)

STEP 1 Bolt Surface Plate to Concrete

Fix the surface plate to an existing concrete slab using concrete bolts (M10x100mm).

STEP 2 Bolt Spigot to Surface Plate

Bolt the spigot plate to the surface plate using the five (5) spigot bolts included with umbrella. Insert the spigot bolts downward through the holes in the spigot plate and screw them into the threaded holes in the surface plate. The spigot bolts should be left just loose enough to allow final adjustment of the orientation of the umbrella if necessary, then once correctly orientated, fully tighten the spigot bolts.

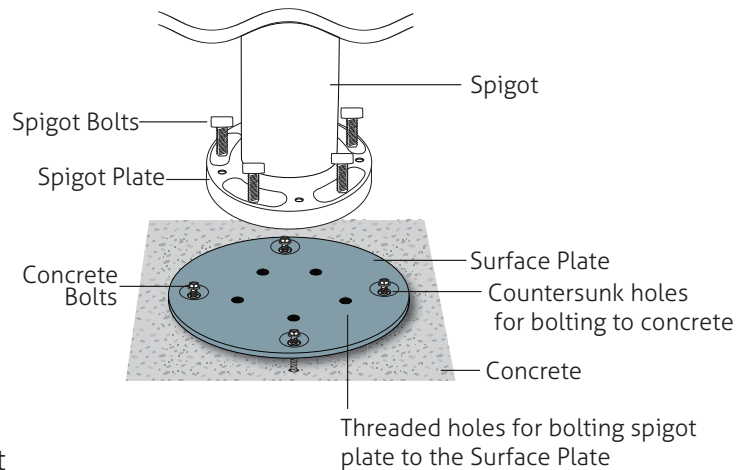

You are now ready to operate your umbrella!

REMOVAL:

To remove your umbrella for seasonal storage or to move it to another surface plate or in-ground anchor, simply undo the spigot bolts and remove the umbrella from the surface plate.

OPTION 3 - Surface Plate (Timber Deck Mount)

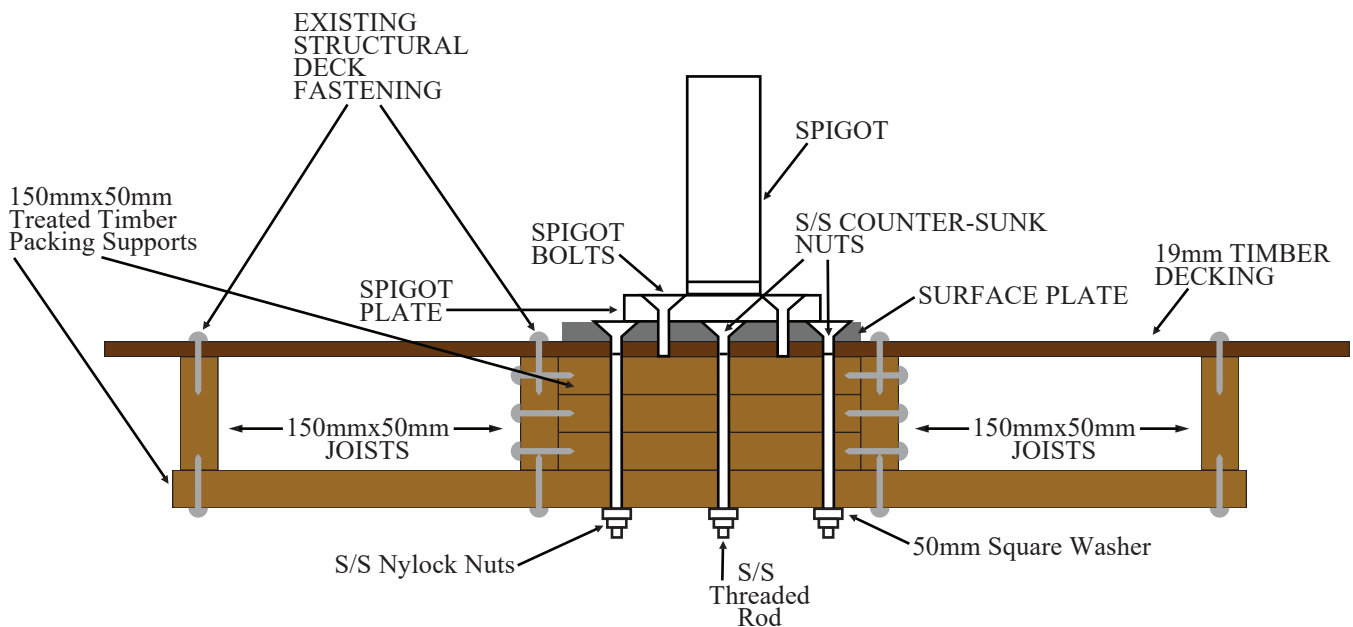

STEP 1 Firstly fix Surface Plate to the timber deck using four stainless steel counter-sunk bolts or similar (refer diagram above). Bolt through the surface plate decking timber and something solid in the deck framing such as a brace or nogs (refer example in above diagram). The length of the bolts will depend on the depth of the decking timber and brace/nog/framing.

STEP 2 Bolt Spigot to Surface Plate

Bolt the spigot plate to the surface plate using the five (5) spigot bolts included with umbrella. Insert the spigot bolts downward through the holes in the spigot plate and screw them into the threaded holes in the surface plate. The spigot bolts should be left just loose enough to allow final adjustment of the orientation of the umbrella if necessary, then once correctly orientated, fully tighten the spigot bolts.

You are now ready to operate your umbrella!

OPTION 4 - Portable Base

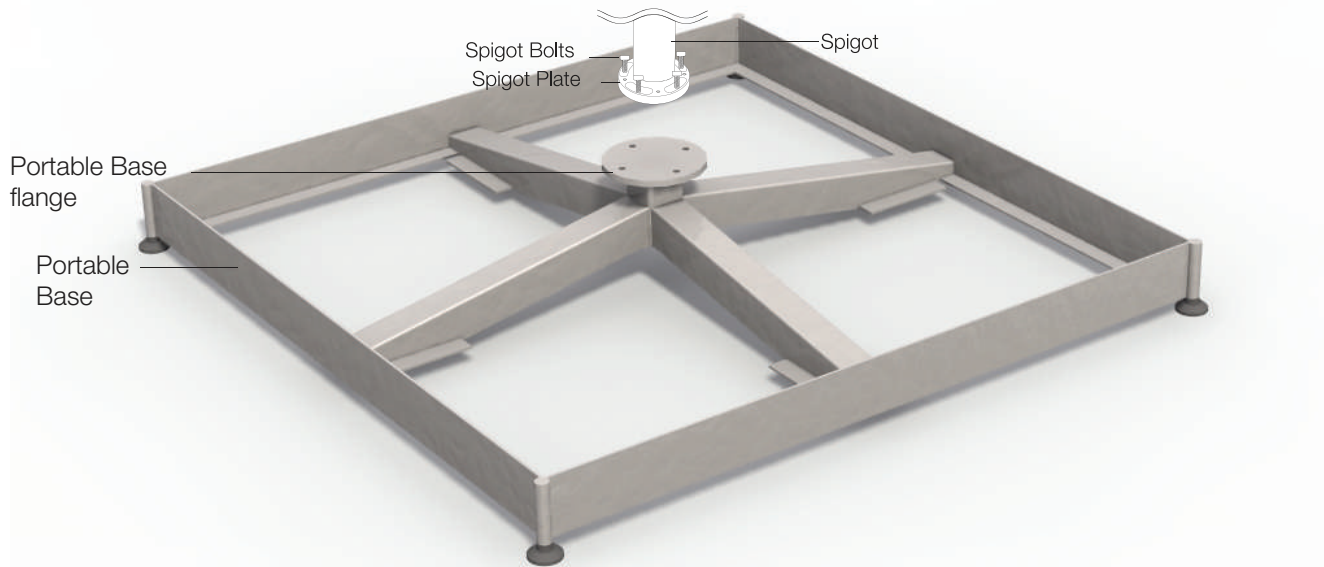

STEP 1 Assemble Portable Base

Attach all four portable base feet to base, one to each corner. Adjust each foot to get base level.

STEP 2 Weight the Base

Weight the base using 8/400mmx400mmx40mm concrete pavers, two layers per quarter. For windy locations, it is advisable to add a third layer of pavers (12 in total)

STEP 3 Bolt Adapter Plate

Bolt the adapter plate to the Portable Base flange using the four (4) bolts provided. Insert the bolts downward through the counter-sunk holes in the adapter plate through the Portable Base flange and tighten the nuts securely.

STEP 4 Bolt Spigot to Adapter Plate

Bolt the spigot plate to the adapter plate using the five (5) spigot bolts included with umbrella. Insert the spigot bolts downward through the holes in the spigot plate and screw them into the threaded holes in the adapter plate. Make sure they are very tight.

NOTE: The Portable Base fixing option is not as secure as the permanent fixings so extra caution needs to be taken in windy conditions.

REMOVAL:

To remove your umbrella for seasonal storage or to move it to another surface plate/ in-ground anchor, simply undo the spigot bolts and remove the umbrella from the in-ground fitting.

STAGE 3 Assembly Notes (Alum Base Pole Cover)

An aluminium Base Pole Cover is supplied with your umbrella. It is recommended this be assembled to the umbrella before bolting the umbrella to its fixing.

To do this, remove the spigot from the umbrella mast by first removing the three small screws (refer diagram below) and slide the spigot out of the umbrella mast. Next slide the aluminium Base Pole Cover over the spigot then slide the umbrella mast back down over the spigot and replace and fully tighten the screws (refer diagram near bottom of page). The finished result should look as per the image below.

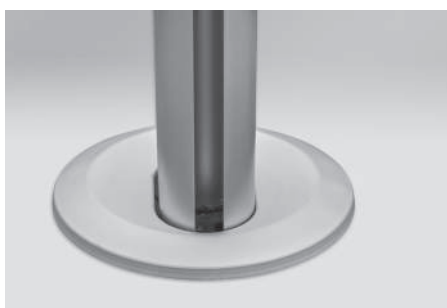

Two Person Install

The SU4 Umbrella is supplied with the spigot already bolted in place to the umbrella mast. The spigot plate can be bolted to the In-ground Anchor/Surface Plate/Portable Base with the umbrella left fixed to the spigot if 2 people are available for the install.

One Person Install

If not able to have 2 people on-site for the install, remove the spigot from the umbrella mast by first removing the three small screws (refer diagram below) and slide the spigot out of the umbrella mast. Bolt the spigot plate to the In-ground Anchor/Surface Plate/Portable Base then slide the umbrella mast back down over the spigot and replace and fully tighten the screws (refer to diagram below).

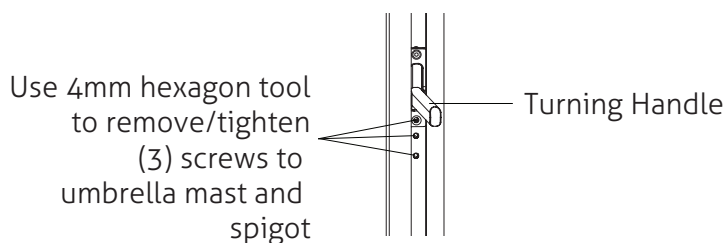

Once the umbrella mast is properly seated and bolted to the spigot, it will not lift off.

You are now ready to operate your umbrella!

STAGE 4 Operating the Umbrella

Your Shadowspec SU4 Umbrella has three positions, apart from closed:

- (1) Tilt position 1
- (2) Tilt position 2
- (3) Horizontal position

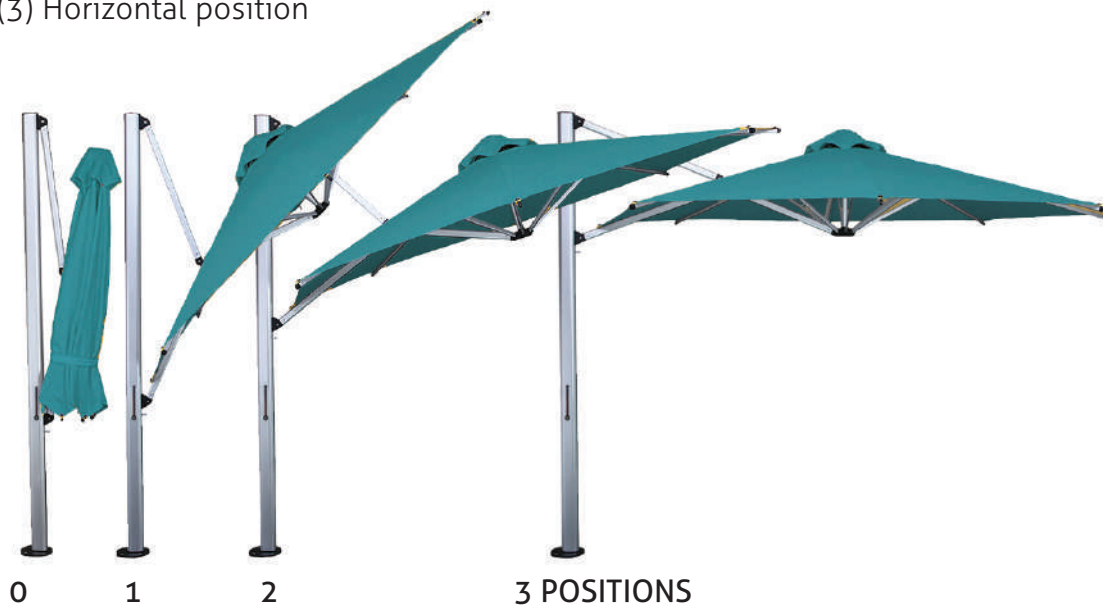

Positions

- 0 Closed position
- 1 Tilt position 1 – blocks extremely angular sun
- 2 Tilt position 2 – blocks moderately angular sun
- 3 Horizontal position

NOTE – DO NOT USE the tilt positions in windy conditions.

TO OPEN THE SU4 UMBRELLA CANOPY

The following instructions will walk you through the sequential progression of opening the su4 umbrella as shown in the picture on the previous page. At any time, you may skip a position and open to the desired position.

OPEN TO THE FIRST POSITION

1. Remove the strap that holds the SU4 umbrella to the mast when in the closed position. Take note of the “parachute” folding method used to fold the canopy when closed. See TO PROPERLY FOLD THE SU4 CANOPY section for more details.
2. Make sure your slider car stop pin is in the ready or horizontal position (A).
3. Begin turning the winder handle clockwise (B) until the slider car stop pin auto locates into the lowest predetermined hole. Continue winding until the canopy is taut. The canopy will now be in Tilt position 1.



CAUTION: NEVER FORCE THE ARMS OPEN IF YOU FEEL RESISTANCE IN THE WINDER!

If you feel resistance in the winder, you should manually pull out a few arms to help facilitate winding (C).

OPEN TO THE SECOND POSITION

1. Open the winder handle and turn counter-clockwise for a few revolutions to release the pressure.
2. With your slider car stop pin again in the ready or horizontal position, quickly pull out the pin (making sure it stays in the horizontal position), and let it slide up the slider car manually until the pin locates in the next predetermined hole. It may be necessary to turn the winder a few times until the pin locates into the hole. Once the pin is located in the hole, continue winding until the canopy is taut. The canopy will now be in Tilt position 2.

OPEN TO THE THIRD POSITION

1. Repeat steps 1-3 outlined above.
2. The canopy will now be in the Horizontal position

HELPFUL HINT: At any time, you may skip a position and open to the desired position by turning the slider car stop pin parallel with the mast. In this position, the pin will NOT auto locate as it passes over the predetermined holes. If you choose to pass the tilt position(s) and go directly to the horizontal canopy position, you may move the pin into the parallel position and continue winding, but be sure to turn the pin back to the horizontal position before the horizontal canopy position is attained. If you pass the top hole, take the tension out of the canopy and then pull the slider car stop pin down and into the top hole.

TO ROTATE THE SU4 UMBRELLA Laterally THROUGH 360°/ 10 POSITIONS

There are 10 holes at the top of the internal stem.

1. Raise the turning handle (D) and rotate mast to a new position.

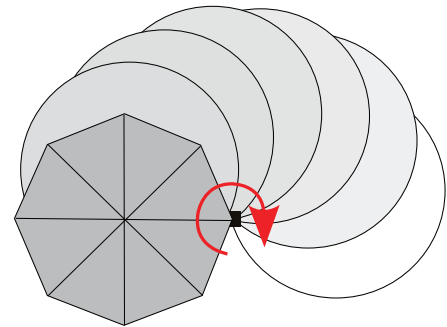
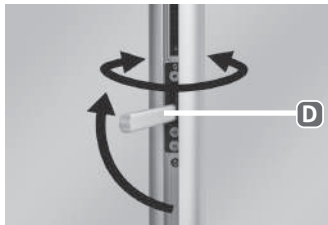

TO LOWER THE SU4 UMBRELLA CANOPY

1. Turn winder handle counter-clockwise (E) for several revolutions until all pressure is released.
2. Reach up and pull slider car stop pin (F) out of hole. Continue to turn counter clockwise to close. If slider locks, pull out.
3. Strap the canopy to the mast with the strap.
4. Pull the Protection Cover over the closed umbrella and zip closed.



TO PROPERLY FOLD THE SU4 UMBRELLA CANOPY

The 100% solution dyed canopy will last longer if you fold it as it was packed and shipped. This technique is similar to the way a parachute is folded and is especially important when folding the SU4 Umbrella canopy for seasonal storage or when the SU4 Umbrella is to be left in the closed position for an extended period of time.

Using this technique at all times will significantly extend the life of the canopy.

1. When the canopy has been fully lowered, stand in front of the canopy structure and begin the folding process by pulling out two panels opposite the mast. Pull the two panels together and roll tight into the canopy.
2. Once rolled tight, pull adjacent panels out one at a time and fold to the center, alternating sides until all the panels have been pulled out from the arms and folded into the center.
3. Strap the canopy to the mast with the strap.



PROTECTIVE COVER

1. Screw rods together and insert into slit of the cover.
2. Unzip cover.
3. Using the rod as a guide, slide cover over your umbrella.
4. Pull on string to zip down your cover and tie.

SECTION 2 – Umbrella Care and Maintenance

Regular care and maintenance of your umbrella is essential.

The following points will assist in keeping it looking smart and clean while also ensuring its ongoing performance and reliability.

- Always place the Protection Cover over the umbrella when not in use.
- Close and cover your umbrella in adverse conditions, this includes rain, snow, hail and high wind.
- Take care when opening or closing the umbrella, always check for obstacles first (ie: trees, ladders, furniture, people).
- Umbrella should never be left stored/collapsed for long periods while wet. Always ensure that the fabric is thoroughly dried before storing or closing for long periods of time.
- Any early signs of mould or mildew must be removed immediately.
- Umbrella canopy is removable and fully washable. Clean fabric using cold or warm water and mild natural soap. Always rinse thoroughly and leave to dry in the open air – **do not** put in clothes dryer.
- Never clean any part of the umbrella with a corrosive/abrasive product or a high pressure hose.
- Never use waterproofing or cleaning sprays on umbrella fabric without seeking appropriate advice first.
- All moving parts on the umbrella are best maintained with an annual application of dry lubricator, such as dry contact silicon spray.

FABRIC CLEANING INSTRUCTIONS:

SHADOWSPEC Umbrella canopies are manufactured from some of the most durable and state-of-the-art marine fabrics and threads available, including Sunbrella and Dickson-Constant acrylic fabrics, along with other proven high-performance, UV stable materials. SHADOWSPEC Umbrella canopies should be cleaned regularly before dirt is allowed to accumulate and become embedded in the fabric. The fabric canopy can be cleaned without being removed from the frame, however, the canopy can be completely removed from the frame if preferred. Simply brush off any loose dirt or particles, hose down and clean with a mild soap in lukewarm water (no more than 37° C.) Rinse thoroughly to remove soap. Allow fabric to air dry. Do not use heavy detergents.

For stubborn stains, '303' Fabric Cleaner is recommended although as with any cleaner, it is advisable to trial a small area of the fabric first to ensure no adverse effect or discolouration occurs. Following cleaning it is also then advisable to re-treat the fabric with a water repellency application again. We recommend '303' Protectant for this purpose.

When washing or cleaning, DO NOT SUBJECT TO EXCESSIVE HEAT as the fabric will shrink. DO NOT STEAM PRESS OR DRY IN ELECTRIC OR GAS DRYERS, but allow air to dry. In cases where the umbrella is taken down and stored during the winter season, the canopy should be cleaned, allowed to air dry, and stored in a dry, well ventilated area. A Protection Cover should be used at all times when umbrella is not in use to ensure the longest serviceable life.

SECTION 3 – Warranty

SHADOWSPEC umbrellas are produced with the greatest care and meet the strictest quality standards.

THE SHADOWSPEC WARRANTY

Unicrest Group Ltd guarantees that Shadowspec umbrellas that are installed in accordance with our guidelines will be free of defects in materials and workmanship for the period of time as set out and specified in the table below:

Model	Umbrella Fabric	Umbrella Frame
Shadowspec SU2	2 Years	4 Years
Shadowspec SU3	2 Years	2 Years
Shadowspec SU4	5 Years	3 Years
Shadowspec SU10	5 Years	3 Years
Shadowspec Serenity™	10 Years	6 Years
Shadowspec Unity™	10 Years	6 Years

*'Fabric' warranty relates to the umbrella fabric canopy. Protection Cover warranty is 2 years for all models

Please note: All time periods as specified in the above table are applied from the date of invoice.

In the case of commercial applications, the guarantee shall be a period of 2 years or the above specified period (whichever is the lesser) from the date of the invoice.

The obligation of Unicrest Group Ltd under this guarantee is limited to faulty manufacturing, defective materials and mechanical failure when the umbrella has been used and cared for appropriately from the date of invoice. If an umbrella is repaired under guarantee the guarantee period will not be extended.

Unicrest Group Ltd shall, at its sole discretion, determine whether repair or replacement is appropriate.

This warranty does not cover the following:

- Damage caused by an accident, negligence, storm, wind, accumulation of water or snow, incorrect installation, not following the maintenance instructions, incorrect use or natural ageing and fading.
- Damage caused by exposure to hazardous atmospheric situations due to industry or a high slat level.
- Small colour variations between the fabric and the colour samples and between the components and profiles, which are caused by the manufacturing process.
- Damage to a third party.
- Repair costs by a third party.

To avoid possible wind damage, it is recommended that your SU4 umbrella be closed in wind gusts exceeding 40km/h. This is subject to the umbrella being sufficiently anchored.

This warranty does protect against the umbrella canopy fabric becoming unserviceable due to strength loss from normal usage and exposure conditions.

The foregoing sets out the extent of this guarantee.

Unicrest Group Ltd shall not otherwise be liable or responsible for any direct, indirect, incidental or consequential damage, costs or losses of any kind arising out of or in connection with the umbrella or components or for any delay by Unicrest Group Ltd or the component manufacturer in undertaking repairs or replacement under this guarantee.

Except as expressly provided herein, all other warranties, representations, conditions, undertakings, rights, duties or liabilities, whether arising by implication of law or otherwise, are hereby expressly excluded.

If you need to make a warranty claim, please contact Unicrest Group Ltd directly or via the agent you purchased through.

New Zealand

Ph: 0800 144 155

Email: info@shadowspec.co.nz

www.shadowspec.co.nz

Australia

Ph: 1800 144 155

Email: info@shadowspec.com.au

www.shadowspec.com.au

USA

Ph: 844 888 5577

Email: info@shadowspec.com

www.shadowspec.com