



shadowspec
umbrellas with distinction

SU3

Wall Mounted Umbrella

OWNERS MANUAL
Installation, Operation,
Care & Guarantee





SU3

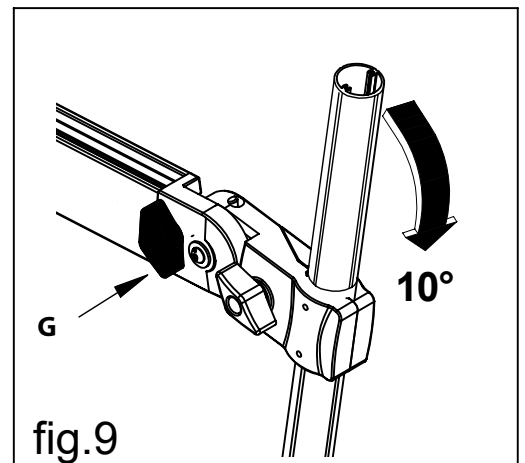
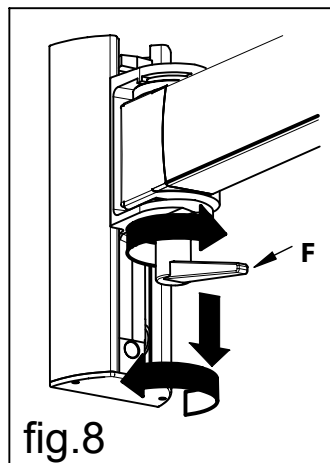
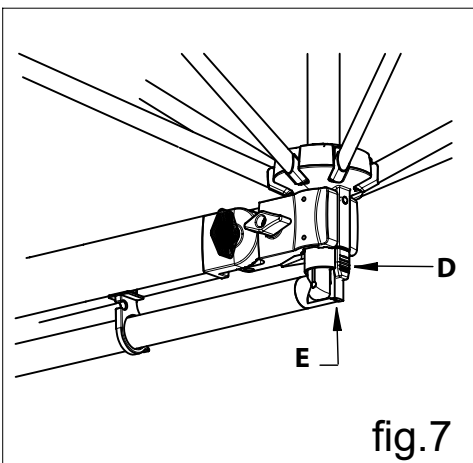
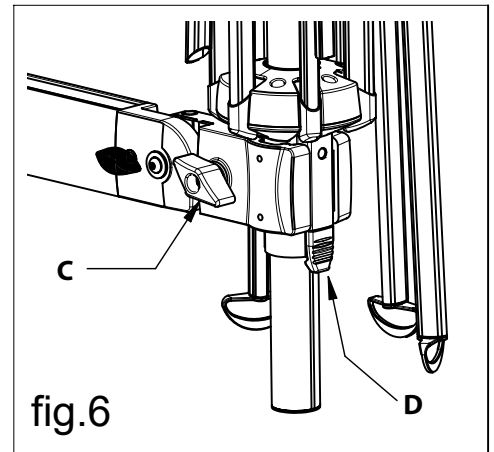
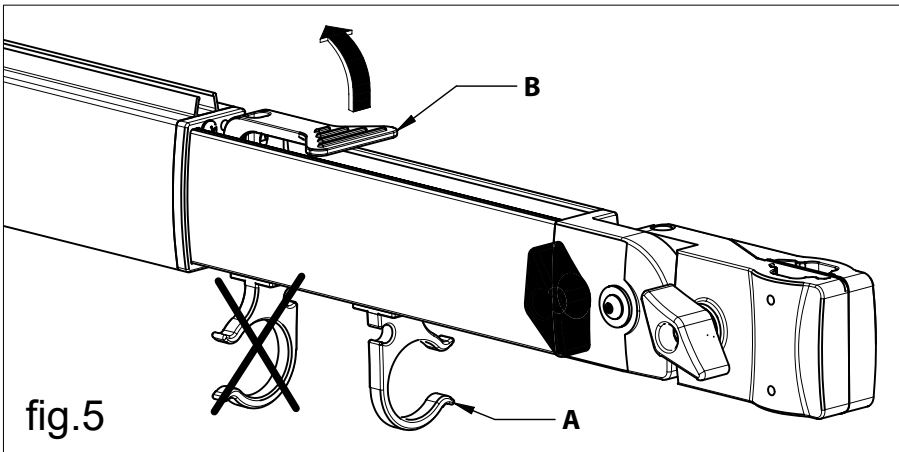
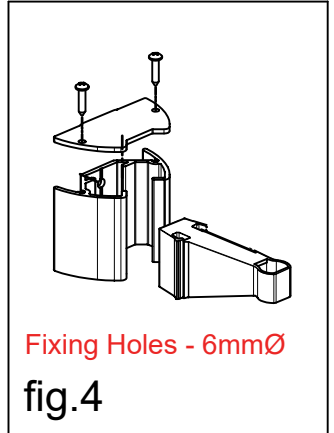
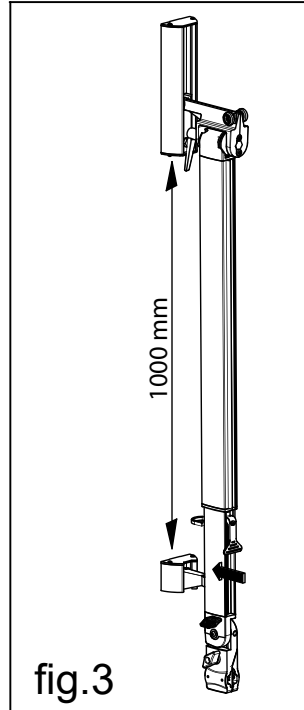
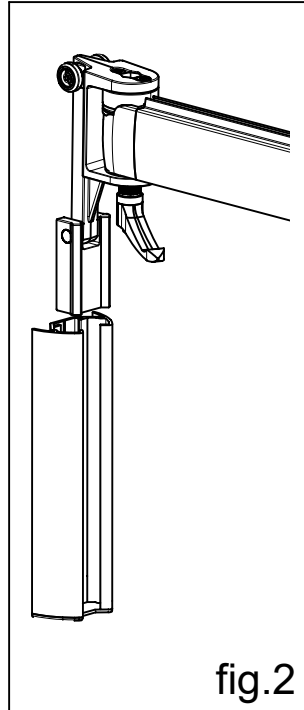
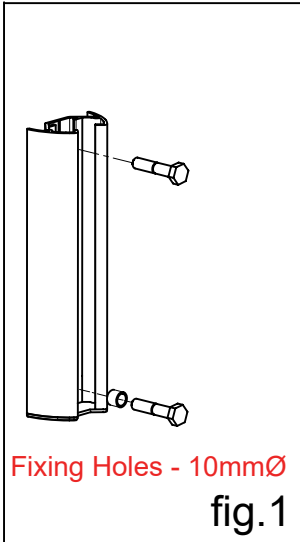

Assembly & Installation

- Step 1** (fig.1) Fix the upper wall bracket on a solid wall or pole. If you have any doubts consult a professional. The advised height to fix the upper wall bracket is +/- 2000mm (this height depends on the height of the operator)
- Step 2** (fig.2) Slide the main support arm into the upper wall bracket
- Step 3** (fig.3) Fix the lower wall bracket to the wall approximately 1000mm below the upper wall bracket.
- Step 4** (fig.4) Assemble lower wall bracket
- Step 5** (fig.5) Lift the main support arm to its horizontal position. Install pole support clip (A) and test telescopic slide by lifting lever (B)
- Step 6** (fig.6) Slide the Umbrella head and pole into the end clamp. Ensure that the Umbrella is orientated with the push button (D) to the front. Check that the fit is neat, then tighten knob (C)
- Step 7** (fig.7) To open the Umbrella - Press button (D) and pull down on the Umbrella pole so that the Umbrella is completely open. **Note that the hinged elbow joint (E) must be clear of the main support arm clamp**, then swing the pole up into the pole support clip.
- Your SU3 Umbrella is now assembled and ready for use.**

Operation

Telescopic Arm 1400-1800mm: To adjust the extension length, lift lever (B) and slide the Umbrella in or out to the desired position.

Horizontal swing: (fig.8) Turn the handle (F) anti-clockwise to loosen. When the Umbrella is swung into its desired position, turn the handle clockwise until tight to lock the Umbrella position. If the handle has been turned a full rotation and it is still not tight, you can pull down on the handle so that it is in free mode and twist it back before releasing the handle allowing it to spring back up and tighten further.

Umbrella Tilt: (fig.9) Pull on knob (G) and the Umbrella will tilt 10 degrees into its tilt position. To set the Umbrella back in its standard position, simply pull on knob (G) again and lift the Umbrella until it locates back in its standard position and the locking knob clicks back into place.

Closing the Umbrella: If still extended, slide the telescopic arm back into its closed position. Remove the Umbrella pole from support clip (A) and swing down so that it hangs vertically. Press button (D) and push the pole up until it clicks into its closed position. While still holding onto the pole, pull knob (G) and lie the Umbrella flat against the main support arm. Now lift the main support arm so that it slides partway up and out of the upper wall bracket exposing the pivot point. The Umbrella can then be lowered down so that it locates into the lower wall bracket.

Always close your SU3 when not in use.



SECTION 2 – Umbrella Care and Maintenance

Regular care and maintenance of your umbrella is essential.

The following points will assist in keeping it looking smart and clean while also ensuring its ongoing performance and reliability.

- Always place the Protection Cover over the umbrella when not in use.
- Close and cover your umbrella in adverse conditions, this includes rain, snow, hail and high wind.
- Take care when opening or closing the umbrella, always check for obstacles first (ie: trees, ladders, furniture, people).
- Umbrella should never be left stored/collapsed for long periods while wet. Always ensure that the fabric is thoroughly dried before storing or closing for long periods of time.
- Any early signs of mould or mildew must be removed immediately.
- Umbrella canopy is removable and fully washable. Clean fabric using cold or warm water and mild natural soap. Always rinse thoroughly and leave to dry in the open air – **do not** put in clothes dryer.
- Never clean any part of the umbrella with a corrosive/abrasive product or a high pressure hose.
- Never use waterproofing or cleaning sprays on umbrella fabric without seeking appropriate advice first.
- All moving parts on the umbrella are best maintained with an annual application of dry lubricator, such as dry contact silicone spray.

FABRIC CLEANING INSTRUCTIONS:

SHADOWSPEC Umbrella canopies are manufactured from some of the most durable and state-of-the-art marine fabrics and threads available, including Sunbrella and Dickson-Constant acrylic fabrics, along with other proven high-performance, UV stable materials. SHADOWSPEC Umbrella canopies should be cleaned regularly before dirt is allowed to accumulate and become embedded in the fabric. The fabric canopy can be cleaned without being removed from the frame, however, the canopy can be completely removed from the frame if preferred. Simply brush off any loose dirt or particles, hose down and clean with a mild soap in lukewarm water (no more than 37° C.) Rinse thoroughly to remove soap. Allow fabric to air dry. Do not use heavy detergents.

For stubborn stains, '303' Fabric Cleaner is recommended although as with any cleaner, it is advisable to trial a small area of the fabric first to ensure no adverse effect or discolouration occurs.

Following cleaning it is also then advisable to re-treat the fabric with a water repellency application again. We recommend '303' Protectant for this purpose.

When washing or cleaning, DO NOT SUBJECT TO EXCESSIVE HEAT as the fabric will shrink. DO NOT STEAM PRESS OR DRY IN ELECTRIC OR GAS DRYERS, but allow air to dry. In cases where the umbrella is taken down and stored during the winter season, the canopy should be cleaned, allowed to air dry, and stored in a dry, well ventilated area. A Protection Cover should be used at all times when umbrella is not in use to ensure the longest serviceable life.

SECTION 3 – Warranty

SHADOWSPEC umbrellas are produced with the greatest care and meet the strictest quality standards.

THE SHADOWSPEC WARRANTY

Unicrest Group Ltd guarantees that Shadowspec umbrellas that are installed in accordance with our guidelines will be free of defects in materials and workmanship for the period of time as set out and specified in the table below:

Model	Umbrella Fabric	Umbrella Frame
Shadowspec SU2	2 Years	4 Years
Shadowspec SU3	2 Years	2 Years
Shadowspec SU4	5 Years	3 Years
Shadowspec SU10	5 Years	3 Years
Shadowspec Serenity™	10 Years	6 Years
Shadowspec Unity™	10 Years	6 Years

*‘Fabric’ warranty relates to the umbrella fabric canopy. Protection Cover warranty is 2 years for all models

Please note:

In the case of commercial applications, the guarantee shall be a period of 2 years or the above specified period (whichever is the lesser) from the date of the invoice.

The obligation of Unicrest Group Ltd under this guarantee is limited to faulty manufacturing, defective materials and mechanical failure when the umbrella has been used and cared for appropriately from the date of invoice. If an umbrella is repaired under guarantee the guarantee period will not be extended.

Unicrest Group Ltd shall, at its sole discretion, determine whether repair or replacement is appropriate.

This warranty does not cover the following:

- Damage caused by an accident, negligence, storm, wind, accumulation of water or snow, incorrect installation, not following the maintenance instructions, incorrect use or natural ageing and fading.
- Damage caused by exposure to hazardous atmospheric situations due to industry or a high slat level.
- Small colour variations between the fabric and the colour samples and between the components and profiles, which are caused by the manufacturing process.
- Damage to a third party.
- Repair costs by a third party.

To avoid possible wind damage, it is recommended that your SU3 umbrella be closed in wind gusts exceeding 20km/h. This is subject to the umbrella being sufficiently anchored.

This warranty does protect against the umbrella canopy fabric becoming unserviceable due to strength loss from normal usage and exposure conditions.

The foregoing sets out the extent of this guarantee.

Unicrest Group Ltd shall not otherwise be liable or responsible for any direct, indirect, incidental or consequential damage, costs or losses of any kind arising out of or in connection with the umbrella or components or for any delay by Unicrest Group Ltd or the component manufacturer in undertaking repairs or replacement under this guarantee.

Except as expressly provided herein, all other warranties, representations, conditions, undertakings, rights, duties or liabilities, whether arising by implication of law or otherwise, are hereby expressly excluded.

If you need to make a warranty claim, please contact Unicrest Group Ltd directly or via the agent you purchased through.

New Zealand

Ph: 0800 144 155

Email: info@shadowspec.co.nz

www.shadowspec.co.nz

Australia

Ph: 1800 144 155

Email: info@shadowspec.com.au

www.shadowspec.com.au

USA

Ph: 844 888 5577

Email: info@shadowspec.com

www.shadowspec.com